



HYDRAULIKVENTILECHNOLOGIE

HVT Pressure Control Valve Type 100

Performance data

Maximum block pressure	350 bar
Valve size	D < 15 mm
Opening pressure	20 - 350 bar, adjustable or permanently set
Flow	< 25 l/min @ 10 bar delta
Internal leakage	< 1 ml/min

This pressure control valve is ideal for virtually all applications in hydraulics and pneumatics thanks to its robust design and construction. The control valve is a preassembled spring-loaded valve designed to limit/hold the pressure in hydraulic systems. The valve is supplied ready for insertion (cartridge) without any mounting and/or sealing elements. All components in contact with media are manufactured of stainless steel. The steel-on-steel valve seat seal design guarantees a long service life.

Other versions available on request



Figure approx. actual size

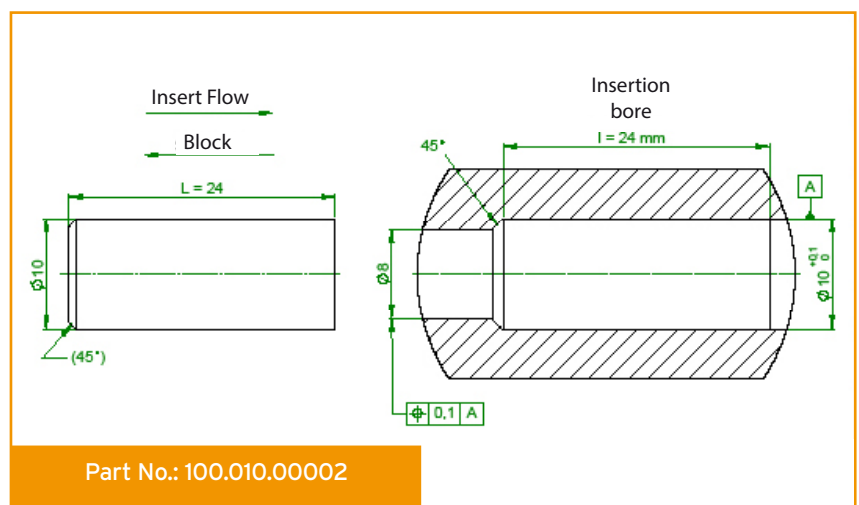

Part No.: 100.010.00002